

KOSO **PARCOL**

noise manual

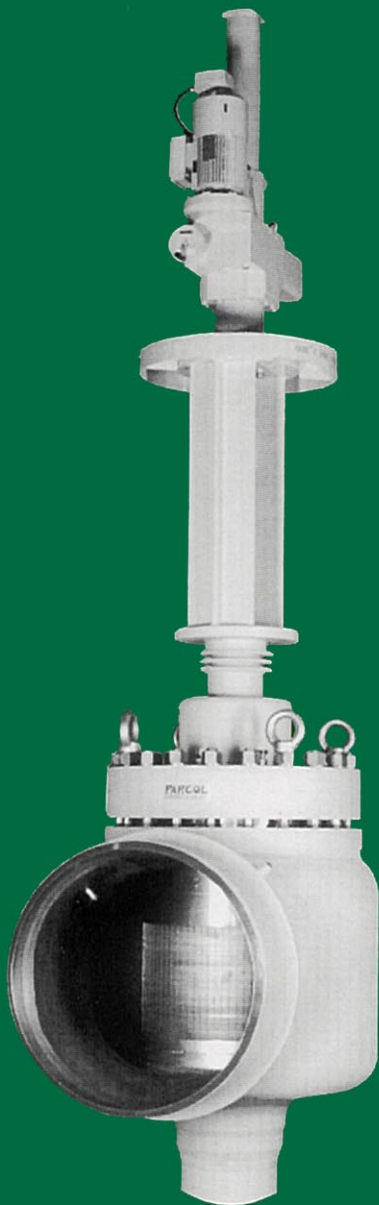

CONTENTS

- 1. Generalities**
- 2. Calculation of sound power**
- 3. Prediction of aerodynamic noise**
- 4. Low noise control valves**
- 5. Influence of piping**
- 6. Vents**
- 7. Acoustic insulation**
- Bibliography**

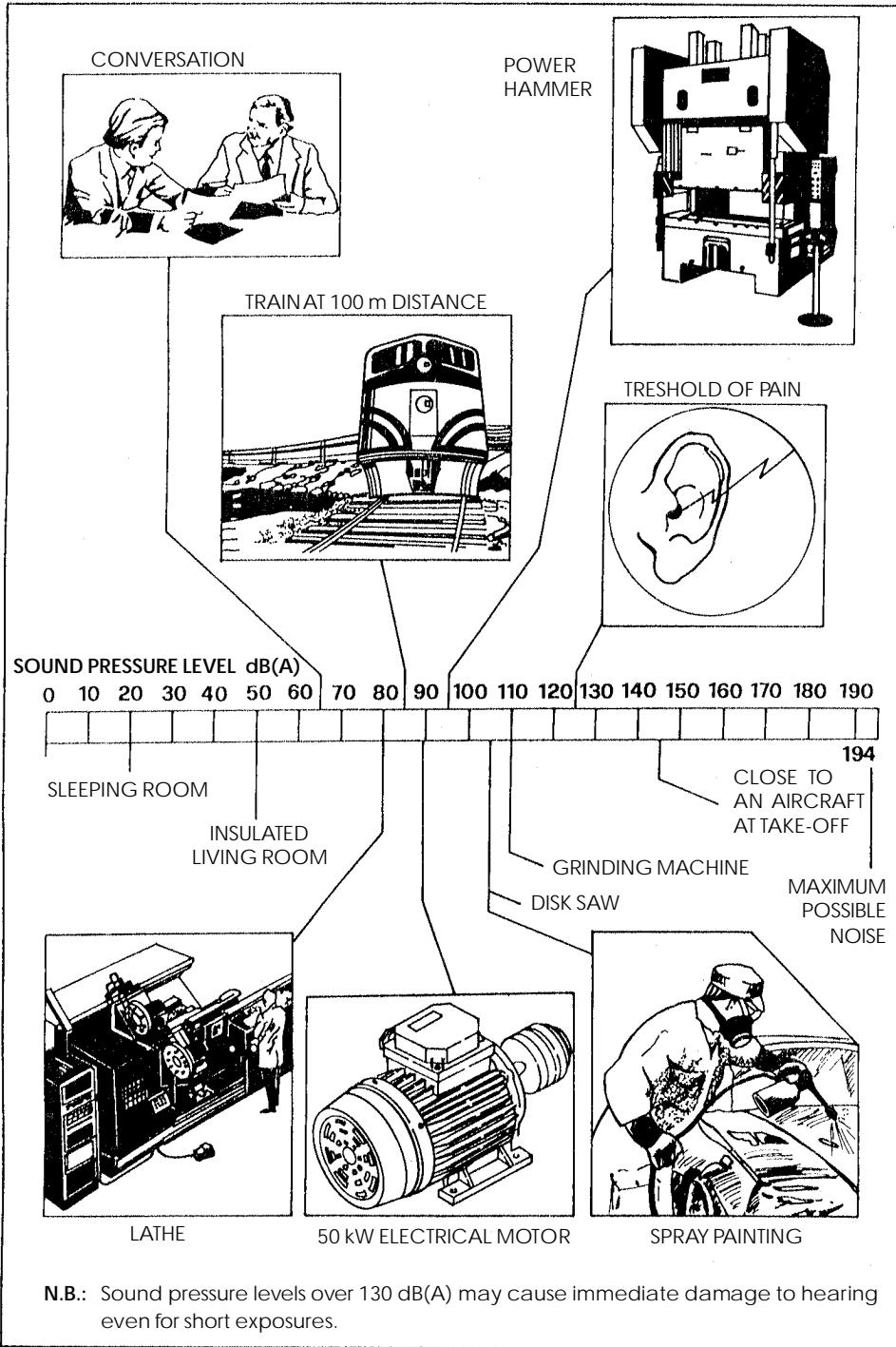

GENERALITIES

The aerodynamic noise is the most important component of the acoustic problem of a control valve, since it is generated by the pressure waves produced by the fluid turbulence or by other fluid dynamic phenomena connected with supersonic waves ("impact cells").

Cavitation and mechanical vibrations are in comparison just potential noise sources, because it is possible to avoid them (at least theoretically), while it is not possible to control a fluid flow rate without generating turbulence.

For this reason the noise is almost ever negligible in case of non cavitating liquids, where the velocity is low, while it is sensible for gas at subsonic conditions and very loud under critical flow condition, where velocity and turbulence become very high.

The aerodynamic noise of conventional valves has not a characteristic acoustic spectrum which can be easily identified, since it has high volumes in a wide range of frequencies between 1000 and 8000 Hz, with prevailing peaks between 2000 and 6000 Hz. Higher frequencies are generated by valves provided with low noise trims, where realized with many small flows arranged in parallel.

The acoustic power generated by a fluid in turbulent flow condition is a function of the mechanical power W_m of the stream and is a small fraction of it, the so called "acoustic efficiency", generally defined as:

$$\eta = \frac{W_a}{W_m}$$

where:

$$W_m = 1/2 \cdot q_m \cdot u^2 \quad (W \text{ in watt, } q_m \text{ in kg/s, } u \text{ in m/s})$$

In case of freely expanded jets the problem is rather simple, because, beside the fact that there are neither downstream piping nor other shape constraints, all the mechanical energy W_m changes to turbulence.

For valves, on the contrary, suitable parameters must be involved, to take into account the acoustic attenuation of the piping, the body shape and mainly the incomplete transformation of W_m into turbulent flow due to the pressure recovery after the throttling section.

The most important of such parameters is the recovery coefficient F_L , which, at subsonic flow conditions, represents the energy fraction wasted inside the valve.

The diagram of Fig. 1 shows the energetic process taking place inside the valve and emphasizes the role of F_L coefficient.

The entropy increase is caused by turbulence and frictions generated mainly downstream the vena contracta.

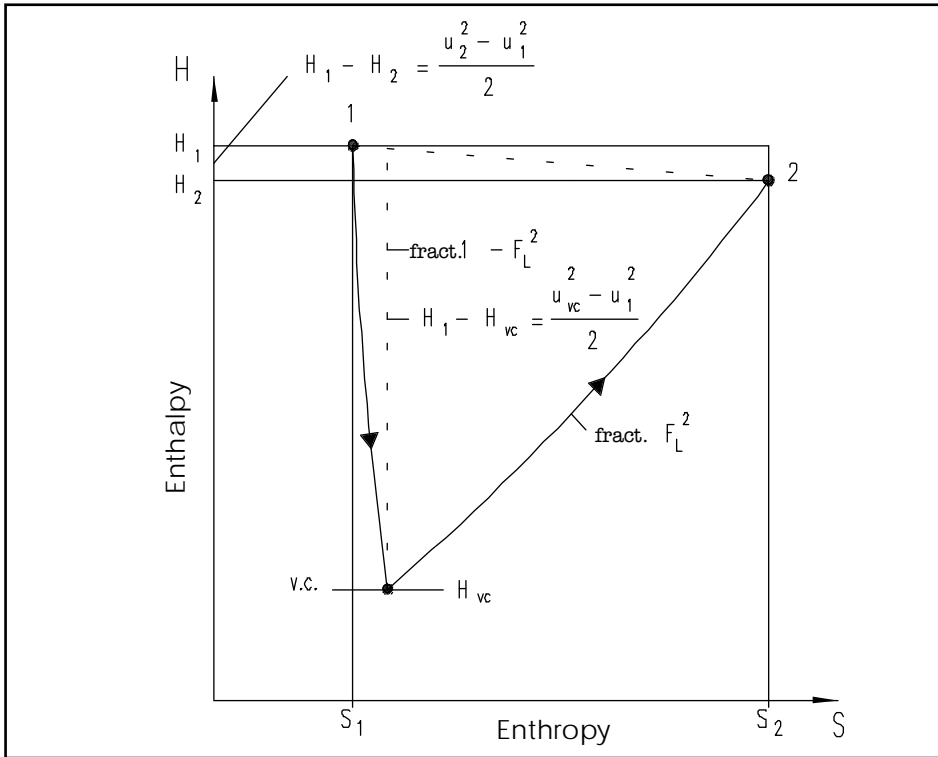

Fig. 1 Thermodynamic balance inside the valve

The enthalpy decrease between inlet and outlet takes place only where the kinetic energy increases.

Fig. 2 shows the fluidynamic processes which take place inside the valve as a function of pressure and more exactly as a function of p_2 changes while p_1 is constant.

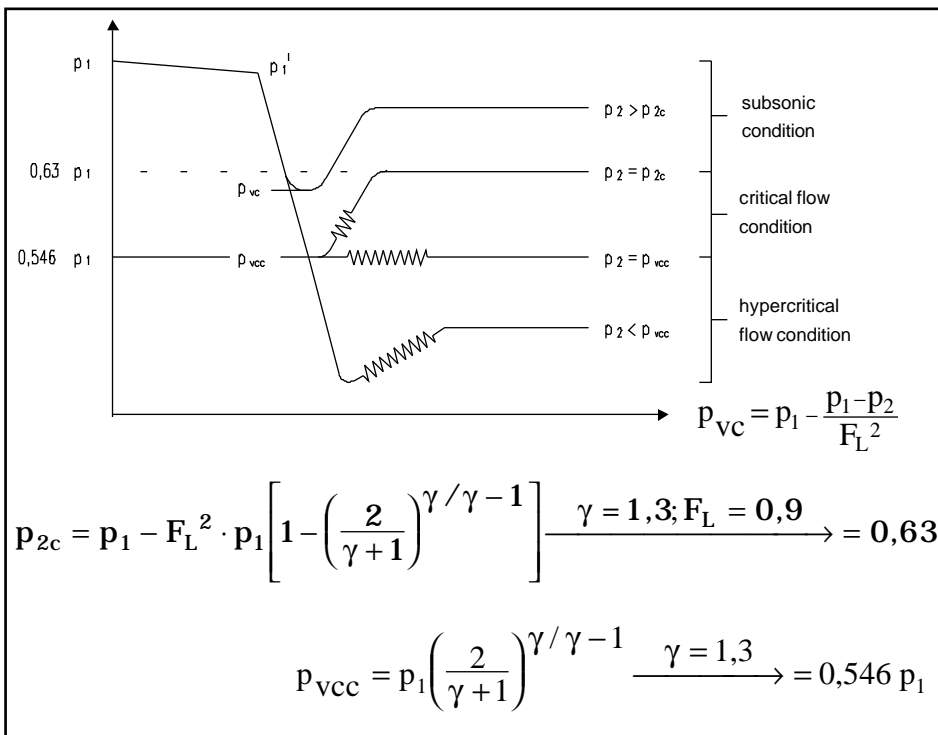

Fig. 2 Pressure run inside a single stage control valve for $F_L = 0,9$ servicing water steam ($\gamma = cp/cv = 1,3$, $p_1 = p_1'$)

The fluid dynamic processes can be summarized as follows :

- 1. Subsonic flow condition** ($p_2 \geq p_{2C}$, where p_{2C} is the downstream pressure, corresponding to the threshold of criticality).

Under this condition part of the mechanical energy existing in vena contracta is recovered as pressure energy downstream the vena contracta. The remaining energy is wasted by turbulence, thus changing into heat and noise.

- 2. Critical flow condition** ($p_{2C} > p_2 \geq p_{VCC}$, where p_{VCC} is the pressure in vena contracta under critical flow condition). Under such a condition the fluid speed in vena contracta reaches the sound speed and supersonic impact waves arise downstream. The more p_2 decreases the lower is the fraction of energy isentropically recovered and converted to pressure; this fraction lowers down to zero where p_2 reaches the p_{VCC} value.

Under this condition a loud noise is given out, due to the fact that the sound velocity is reached and other complex aerodynamic disturbances are generated.

- 3. The hypercritical flow condition** takes place where $p_2 < p_{VCC}$. The energetic meaning of F_L is not valid any longer since no isentropic pressure recovery takes place.

All of the fluid kinetic energy in vena contracta is wasted in interferences among supersonic impact waves.

CALCULATION OF ACOUSTIC POWER

Equations for calculation of η and W_a for different flow conditions are summarized in the table of Fig. 3.

For more detailed analysis of this argument see the documents listed in bibliography under [1] [2] [3] [4] [5].

Acoustic efficiency is plotted in Fig. 4 versus p_1/p_2 for different F_L values.

It is interesting to remark the particular dependence of acoustic power on recovery factor F_L .

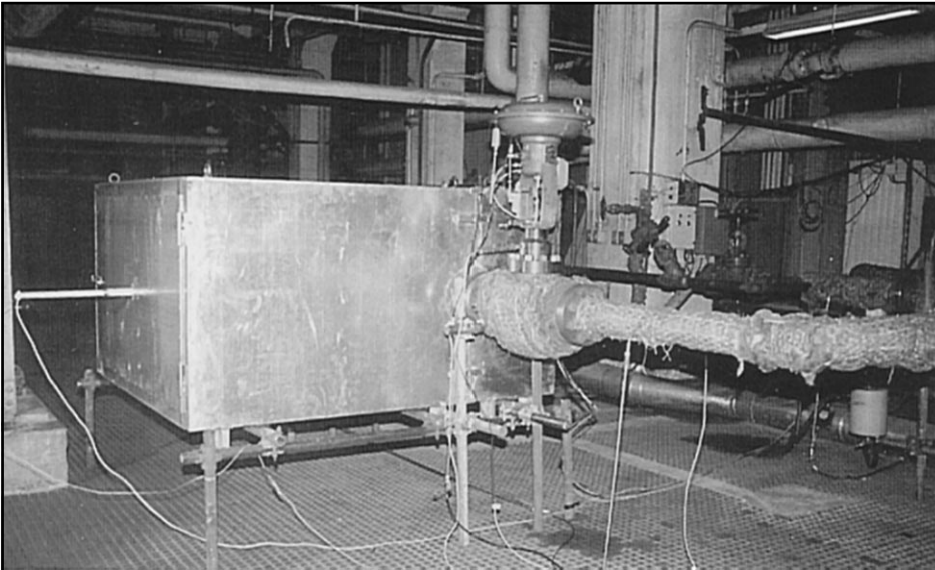

Noise test on 1-9111 Limiphon control valve DN 3" x 4" carried out on steam. Upstream pressure = 92 bar abs, upstream temperature = 485°C. Tests have been performed in accordance with IEC 534-8-1, measuring noise level in an anechoic chamber, at SIET SpA - Piacenza - ITALY

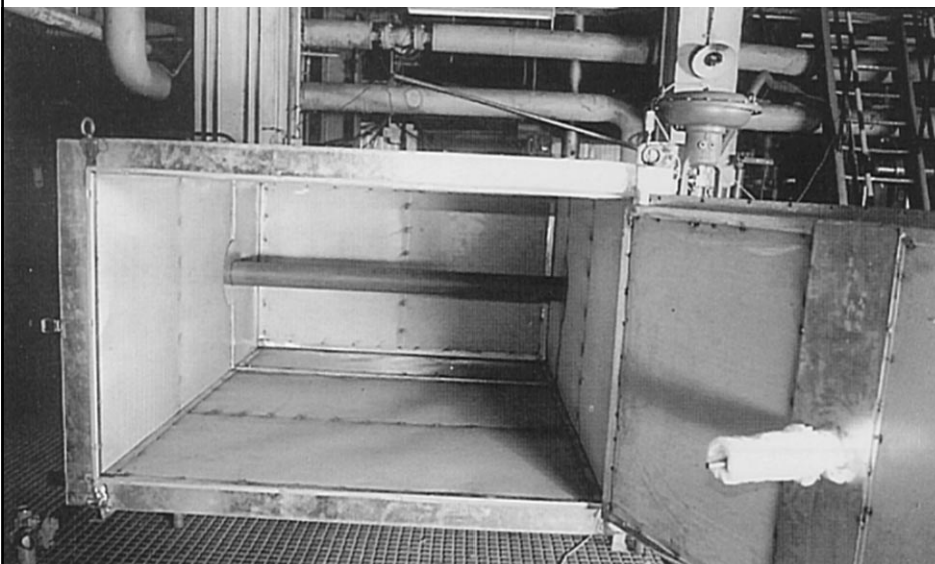

Flow condition	Subsonic	Critical	Hypercritical
cause of aerodynamic noise	turbulence downstream of v.c.	turbulence + supersonic impact waves	supersonic impact waves
P_2	$P_2 \geq P_{2c}$	$P_{VCC} \leq P_2 < P_{2c}$	$P_2 < \frac{P_1 \cdot P_{2c}}{22 \cdot P_{VCC}}$
P_{VC}	—		
P_{VCC}	/		$P_1 \left(\frac{2}{\gamma+1} \right)^{\frac{\gamma}{\gamma-1}}$
P_{2c}	$P_1 - F_L^2 \cdot (P_1 - P_{VCC})$		
M_{VC}	$\sqrt{\frac{2 \cdot P_1 \cdot M}{(\gamma-1) \cdot \rho_1 \cdot R \cdot T_1} \left[\left(\frac{P_1}{P_{VC}} \right)^{\frac{\gamma-1}{\gamma}} - 1 \right]}$	/	/
M_j	/	$\sqrt{\frac{2}{\gamma-1} \left[\left(\frac{P_1 \cdot P_{2c}}{P_2 \cdot P_{VCC}} \right)^{\frac{\gamma-1}{\gamma}} - 1 \right]}$	/
acoustic efficiency η	$10^{-4} \cdot M_{VC}^{3,6}$	$10^{-4} \cdot M_j^{6,6} F_L^2$	$10^{-4} \cdot \frac{M_j^2}{2} \cdot 1,4^{6,6} F_L^2$
Wa	$\eta \cdot F_L^2 \cdot Wm$	$\eta \cdot Wm \frac{P_1 - P_2}{P_1 - P_{VCC}}$	$\eta \cdot Wm$

Fig. 3 Acoustic efficiency and power for different flow conditions

Fig. 4
 Acoustic efficiency -
 as a function of p_1/p_2 and of F_L
 for $\gamma = 1.3$ -

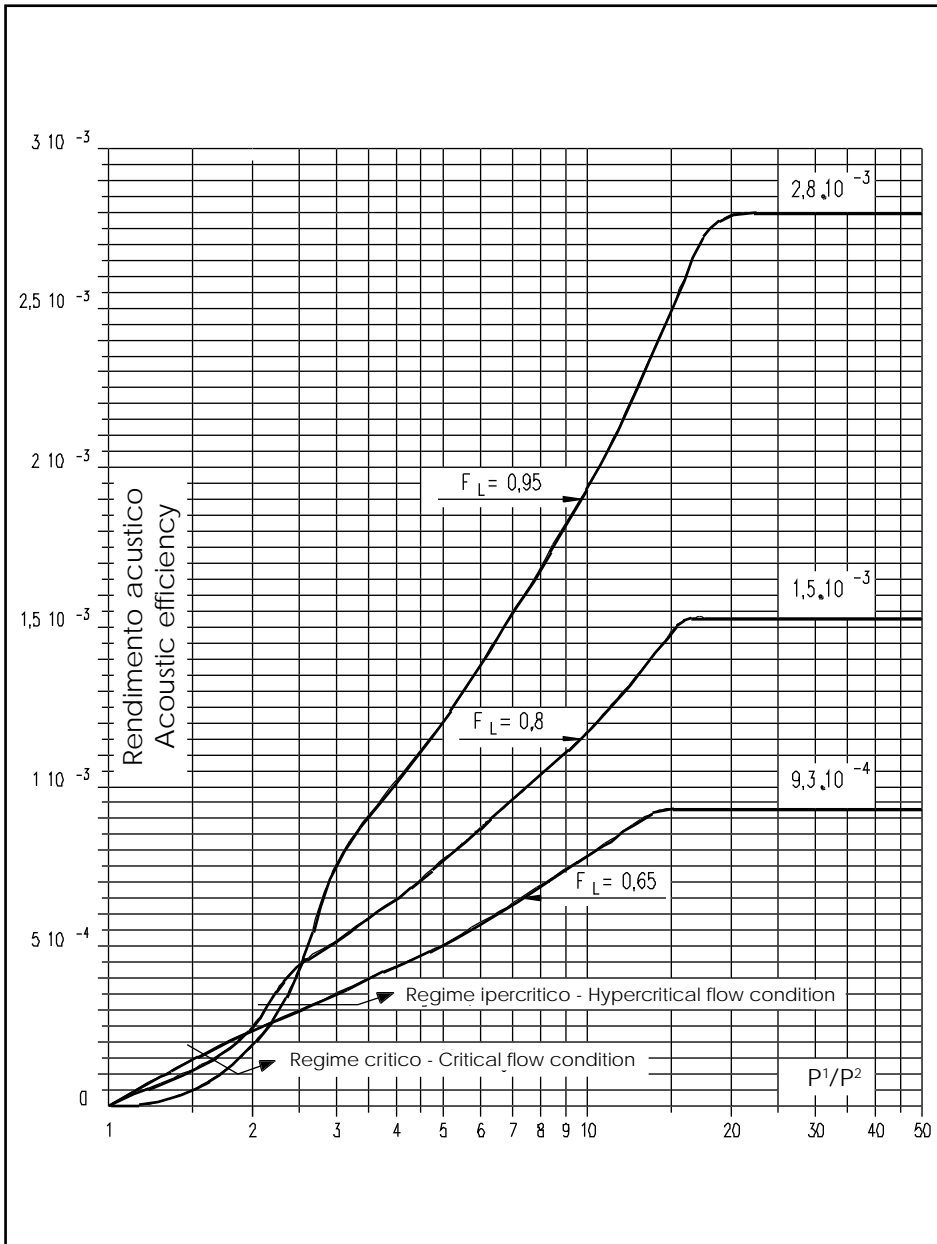

PREDICTION OF AERODYNAMIC NOISE

3.1 EQUATION FOR CALCULATION

The acoustic power W_a generated by the fluid inside the valve is obtained by means of equations shown in Fig. 3.

For the calculation of sound pressure level L_p refer to the following equation:

$$W = S \frac{p^2}{\rho \cdot c}$$

where S is the flow sectional area of the sound wave, p is the acoustic pressure and $\rho \cdot c$ the media impedance.

Due to the particular characteristic of the assembly valve+piping, the application of this equation is rather complex, since the following factors are involved in the calculation:

1. The integration surface of sound power
2. The fraction of acoustic power transmitted to adjacent piping [5]
3. The frequency distribution of the generated noise [5]
4. The effect of fluid velocity inside the piping
5. The acoustic attenuation of the piping

Here it is the final equation for the calculation of the sound pressure level:

$$L_p(A) = 160 + 10 \log \frac{W_a \rho_2 \cdot c_2 \cdot r_w}{\pi D_i^2} + L_g + \Delta_{sp} - 10 \log \frac{D_i + 2000}{D_i} + T_{Lfp} \quad (1)$$

where:

$L_p(A)$ = A-weighted sound pressure level, measured at 1 m distance from valve outlet and 1 m distance from the bare pipe wall

r_w = fraction of acoustic power transmitted downstream - for values see table of Fig. 5

L_g = correction for downstream velocity = $16 \log \frac{1}{1-M_2}$

Δ_{sp} = correction factor of spectrum - see table of Fig. 6

Types of PARCOL valves	r_w
1-6951; 1-6921; 1-6981; three ways straight flow; LIMIPHON valve 1-9100; straight flow globe valve 1-6932; double seat microflow valve	0.25
angle valve 1-4411; cage valve 1-4432; three ways angle valve; LIMIPHON valve 1-9400	0.3
120° angle valve 1-4200; diaphragm valve 1-3000; butterfly valve up to 45° even at critical flow condition and up to 90° at subsonic condition.	0.4
butterfly valve 1-2471; 1-2311; 1-2512 from 45° to 90° in critical flow condition - drilled disks	0.5

Fig. 5 r_w values for different valve types

The equation (1) is valid for single stage valves. For multistage valves the sound power is calculated in the last stage by substituting p_1 with the upstream pressure p_n .

In equation (1) a supplementary term takes into account the acoustic power generated by upstream stages.

Δsp correction factor of spectrum			
PARCOL valve type	Butterfly valve 1-2471 1-2311 1-2512	Globe valve 1-6911, 1-4411 Cage conventional valves 1-2473, 1-7251	Cage valve GBR LIMIPHON valve
DN 4"	9,5	3	-5
DN 8"	8,5	2	0
DN 16"	6	-1	+5

Fig. 6 Medium values applicable for valve opening 50% and over -

3.2 VALIDITY AND TOLERANCES

The equation (1) is valid under the following hypothesis:

- 1. Isotropy of the source**, which must be free to irradiate in any direction.

In case of control valves (cylindrical source) this situation involves a 3 dB noise reduction when doubling the distance. The presence of walls close to the valve modifies this ideal situation by increasing the sound level compared to the calculated one.

For instance, where the valve is mounted over a reflecting floor, the sound pressure level is increased by about 3 dB.

- 2. Absence of foreign disturbances**

The sound pressure level calculated using the equation (1) is the one generated by the valve. Eventual other sources must be taken into account by suitable correction factors.

- 3. Correct installation**

The valve must be inserted in the piping according to suggestions outlined under point 5.

- 4. The tolerance** on noise estimation depends on the valve type which the equation (1) is used for.

The expected tolerance range is ± 5 dB, except for rotary valves having a sophisticated design, desuperheating valves fitted with inside water injection and low noise constructions with not exactly defined and not independent paths.

NOMENCLATURE

SYMBOL	DESCRIPTION	UNITS
c_2	= Speed of sound in downstream fluid	m/s
D_j	= Jet diameter	mm
D_i	= Internal pipe diameter	mm
F_d	= Valve style modifier	Dimensionless
f_p	= Generated peak frequency	Hz
f_r	= Pipe own frequency	Hz
$L_p(A)$	= A-weighted sound pressure level external of pipe	dB(A)
L_g	= Correction for velocity in downstream piped	dB(A)
M_2	= Mach number in downstream pipe = $\frac{u_2}{c_2}$	Dimensionless
M_{vc}	= Mach number at vena contracta at subsonic condition	Dimensionless
M_j	= Freely expanded jet Mach number	Dimensionless
p_1	= Valve inlet absolute pressure	Pa
p_2	= Valve outlet absolute pressure	Pa
p_{2c}	= Valve outlet absolute pressure at critical flow conditions	Pa
p_{vc}	= Absolute vena contracta pressure at subsonic flow conditions	Pa
p_{vcc}	= Absolute vena contracta pressure at critical flow conditions	Pa
q_m	= Mass flow rate	kg/s
r_w	= Fraction of acoustic power transmitted downstream	Dimensionless
S	= Pipe wall thickness	mm
T_{Lfp}	= Acoustic attenuation at peak frequency	dB
T_L	= Acoustic attenuation	dB
Δ_{sp}	= Spectrum correction factor	dB
u_2	= Average fluid velocity in downstream pipe	m/s
u_{vc}	= Fluid velocity in the vena contracta	m/s
W_a	= Acoustic power	W
W_m	= Stream power of mass flow	W
W_{m_2}	= Stream power at valve outlet	W
$W_{m_{vc}}$	= Stream power in the vena contracta	W
η	= Acoustic efficiency	Dimensionless
ρ_2	= Density of fluid at valve outlet	kg/m ³
γ	= Specific heat ratio = c_p/c_v	Dimensionless

3.3 ACOUSTIC ATTENUATION

It is utmost necessary to know the acoustic attenuation of the piping to predict the noise of control valves, mainly to design low noise ones.

Thanks to convenient approximations, a calculation method was recently achieved [1], suitable for low noise valves; the most important feature of this method is the choice of the noise **peak frequency** as an essential variable for T_L calculation.

Under the hypothesis that noise frequency f_p is higher than the own piping frequency f_r (mass action law validity) and that coincidence frequencies are lower than resonance frequencies, the acoustic attenuation T_L can be calculated using the following equation:

$$T_{Lfp} = 10 \log \left[3 \cdot 10^{-13} \cdot \left(c_2 \frac{D_i}{S} \right)^2 \frac{1}{\frac{\rho_2 \cdot c_2}{415} + 1} \right] - 20 \log \frac{f_p}{f_r} \quad (2)$$

where the first term represents T_L at frequency f_r and the second one the correction for peak frequency f_p .

The noise peak frequency f_p can also be evaluated theoretically as a function of flow condition (subsonic, critical or hypercritical) and of trim geometric shape.

For instance, for subsonic flow condition (common in valves provided with low noise trim) the peak frequency can be calculated using the equation:

$$f_p = 200 \cdot \frac{u_{vc}}{D_j} \quad (3)$$

where D_j is the equivalent diameter of the jet at trim outlet, which is a typical constructive data of each trim type. It is directly proportional to the trim shape factor F_d , whose typical values are listed in Fig. 7 table:

$$D_j = 4,6 \cdot 10^{-3} \cdot F_d \cdot \sqrt{C_v \cdot F_L} \quad (4)$$

Valve type		Valve style modifier F_d		
		Flow direction	Relative flow coefficient	
			0.10	1.00
Globe, parabolic plug (1-6911, 1-6951, 1-6921, 1-6981 e 1-4411)		Flow-to-open	0.10	0.46
		Flow-to-close	0.20	1.00
Butterfly valve 1-2471, 1-2512, 1-2311	<u>Max. opening</u> 90°	Whatever	0.20	0.7
	60°		0.20	0.5
Cage valve 1-6931, 1-4432, 1-6971, 1-4471	<u>Number of holes</u> 50	Whatever	0.45	0.14
	100		0.32	0.10
	200		0.22	0.07
Double seat 1-8110	Parabolic V-port	Between seats	0.10	0.32
			0.10	0.28

Fig. 7 Typical F_d values for PARCOL control valves.
More accurate values available on request

LOW NOISE CONTROL VALVES

4.1 DESIGN GUIDELINES

Theoretical principles for the calculation of control valve noise practically define the design guidelines of low noise series.

The above can be easily shown by considering the two basic parameters of control valve noise:

acoustic efficiency and **peak frequency**.

4.2 ACOUSTIC EFFICIENCY - MULTISTAGE TRIMS

Fig. 5 shows that (for $F_L \cong 0.9$) the ratio of acoustic efficiencies between hypercritical flow condition, with $p_1/p_2 > 10$, and the subsonic one, with $p_1/p_2 = 1.5$, can arrive up to 30 max, which, according to equation (1), corresponds to ΔL_p value of 15 dB for the noise inside the piping.

The above acoustic advantage can be therefore achieved on condition that the fluid leaves the trim under subsonic flow condition.

Where high pressure drops must be performed the above is only possible by using a trim provided with a suitable number of multiple stages arranged in series.

A practical specimen of this trim type is the PARCOL valve series 1-7251, shown in Fig. 8. The special plug design allows to split the pressure drop into more steps along the winding path created between plug and fixed shaped outside wall.

It is remarkable the fact that the pressure drop takes place through the single stages simultaneously with the flow sectional area reduction; this is the basic condition for the good flow control quality.

The practical limits of this solution are of constructive nature and can be summarized as follows:

1. Maximum number of feasible stages
2. The expansion ratio of sections from inlet to outlet, which in the aforementioned case should be at least 30:1. As a matter of fact it is not sufficient to take care of critical steps without minding the fluid velocity inside the trim.
3. Maximum required Cv.

Fig. 8 *Low noise design 1-7251 provided with multistage single path trim.*

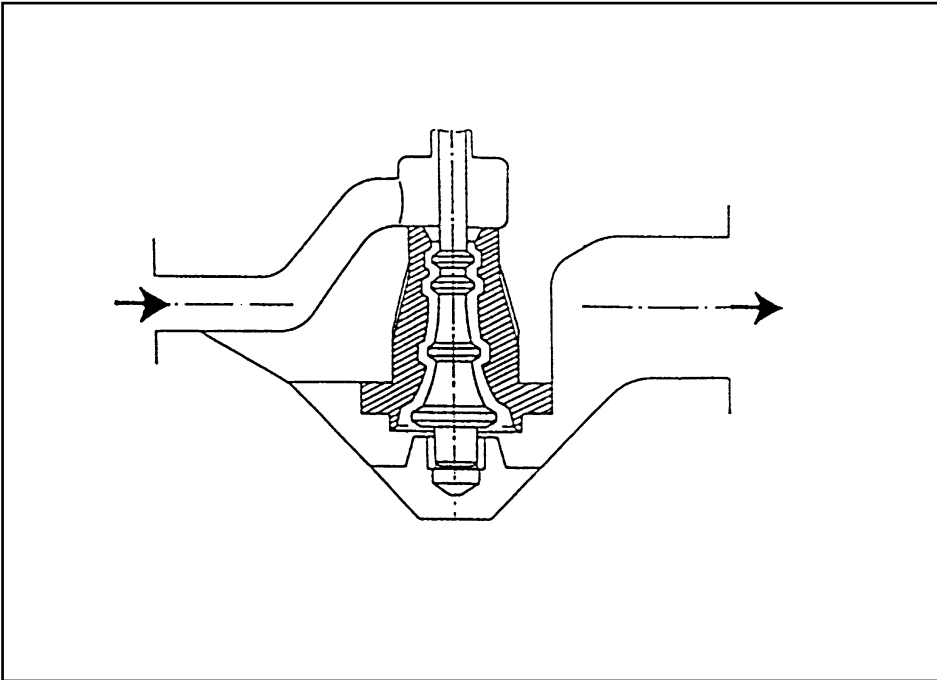
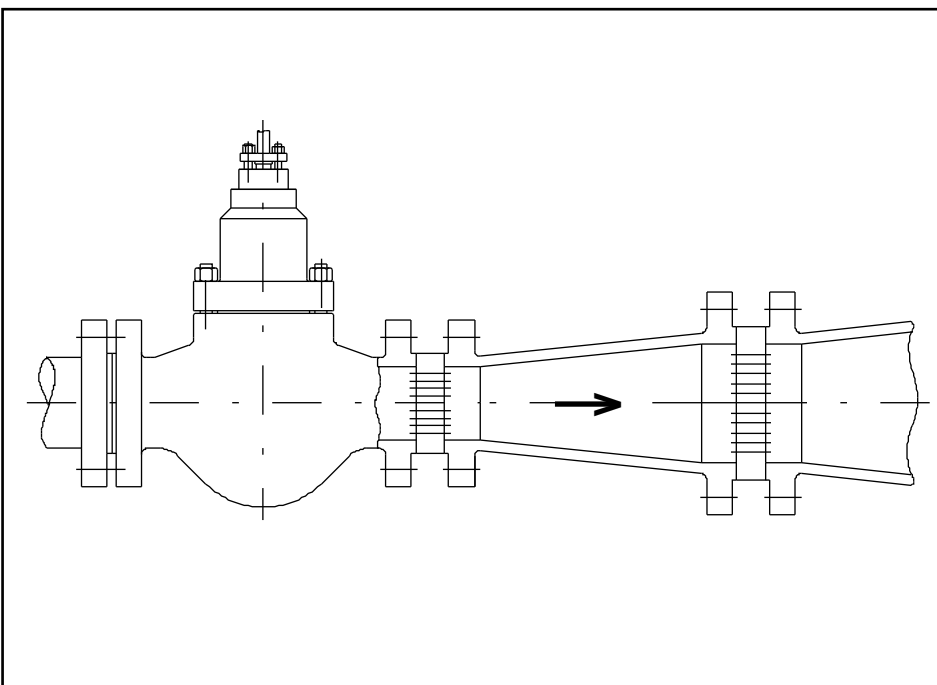

Fig. 9 *Fixed downstream restrictors*



It is possible to try to overcome the first two limitations, mainly the second one, by inserting downstream head losses by fixed sectional area throttles (see Fig. 9).

The above surely makes the multistage valve easier to construct, but the process rangeability gets problematic, both under flow control and acoustic viewpoint.

This solution may only be taken into consideration when the load is rather constant and all of the variables are known versus load changes.

4.3 PEAK FREQUENCY - GBR CAGE TYPE VALVES

Sound pressure levels generated by control valves inside the piping almost always reach very high values.

Luckily the pipe wall acts as a very important acoustic barrier, which lets just a small fraction of sound intensity pass outside. Otherwise the acoustic problem certainly could not be faced neither with the most sophisticated and expensive low noise control valves.

As already seen under point 3.3 the acoustic attenuation of the pipe wall is as stronger as higher is the frequency f_p of the noise compared to the main resonance frequency of the piping.

This law is valid when the noise frequency is higher than f_r , i.e. for high acoustic frequencies (which are the most significant under the acoustic viewpoint) and pipe diameter relatively high (low resonance frequency).

Then here it is a second important guideline to design a low noise trim:

The acoustic spectrum of the generated noise must show higher intensity at high frequencies.

The above can be obtained by knowing all of the acoustic and fluidynamic parameters of the phenomenon, mainly of the valve style modifier F_d :

$$F_d = \frac{d_H}{d_0} \frac{1}{\sqrt{N_0}} \quad (5)$$

where d_H and d_0 are respectively the hydraulic diameter and the one of the total equivalent flow section, while N_0 is the number of independent paths arranged in parallel.

As already seen under point 3.3 the leading frequency f_p is directly proportional to D_j value, i.e. inversely proportional to F_d .

Hence it appears that, at a parity of other geometrical variables, the higher is the number of paths, the higher is f_p and finally the lower is the noise transmitted through the pipe wall.

For conventional single stage valves $N_0 = 1$, except for double seat and butterfly versions, where $N_0 = 2$.

Acoustic benefits deriving from acoustic attenuation are therefore negligible in these cases, since F_d values are high and f_p values are low.



Fig. 10 *GBR type single cage -
The noise reduction is obtained by providing a very high number
of low diameter holes (2÷4 mm)
Acoustic attenuation up to 15 dB.*

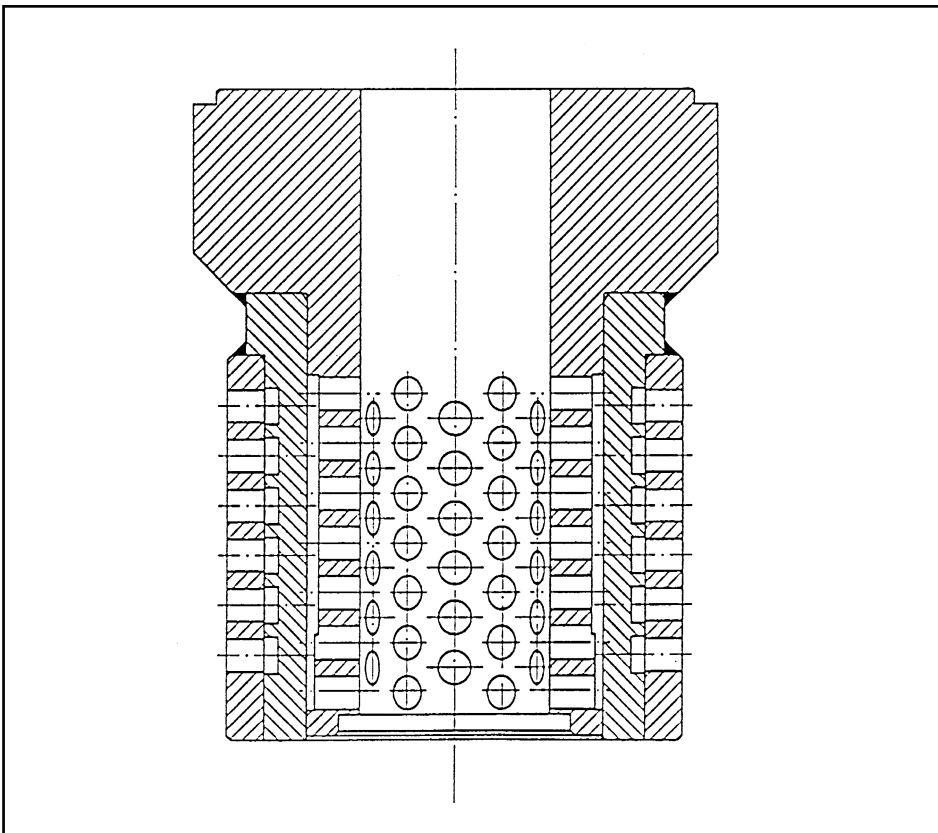

Fig. 11 *Multicage trim -
The limited number of stages and paths does not allow to obtain
an acoustic benefit higher than 10 dB.*

A low noise trim, built on the basis of this theoretical principle, is the PARCOL GBR model shown in Fig. 10.

It is a single cage model (single-stage, multipath) provided with a very high number of small holes. Such a model allows to reach very low values of F_d (even < 0.02), corresponding to f_p values higher than 20 kHz.

The advantage deriving from T_L increase must be added to the contribution of Δsp , which, due to the concentration of intensities around f_p , normally results very low.

4.4 UNIVERSAL SOLUTIONS MULTISTAGE / MULTIPATH - LIMIPHON TYPE TRIM

Single path multistage valve models, like the type mentioned under point 4.2, take advantage from the low acoustic efficiency of sub-sonic flow condition, but their relatively low peak frequencies limit the pipe wall attenuation.

Single stage cage trims mentioned under point 4.3 normally operate under critical flow condition, but their low F_d values and consequently high frequencies allow to profit the noise attenuation due to higher T_L value.

For both the above cases the noise attenuation can reach 15 dB maximum (with reference to conventional models), which for sure represents a quite good acoustic performance, but may be only obtained with a very accurate design and construction.

Since the most severe applications require L_p reductions over 20 dB, multistage/multipass trims were set-up, thus profiting the advantages of the two aforementioned solutions.

A first step toward the realization of this principle is represented by the multicage trim (Fig. 11), which nevertheless can not represent the true problem solution, due to some theoretical and constructive limits .

The final answer to the most severe acoustic problems of control valves is represented of the contrary by the PARCOL Limiphon type trim, shown in Fig. 12, which is realized by overposing metal disks perforated and arranged according to different patterns.

No theoretical limit related with p_1/p_2 ratio, number of stages and speed control exist for such models.



Fig. 12 *Trim of LIMIPHON control valves of universal multistage/multipath type, provided with labyrinth disk stack. Fluid paths are obtained by overposing disks suitably drilled and mutually oriented.*

Fig. 13 shows a typical application of a pressure reducing valve of a methane decompression station.

The construction of this valve type, yet intrinsically complex, becomes very exacting where the fluid temperature is very high.

Fig. 14 shows a HP turbine by-pass valve intended to reduce the pressure of about 250 t/h steam flow rate from 100 to 1.5 bar; its sound pressure level is 90 dB(A) (bare pipe).

This valve type is provided with a very low specific Cv trim and generally requires a very long travel compared to other models.

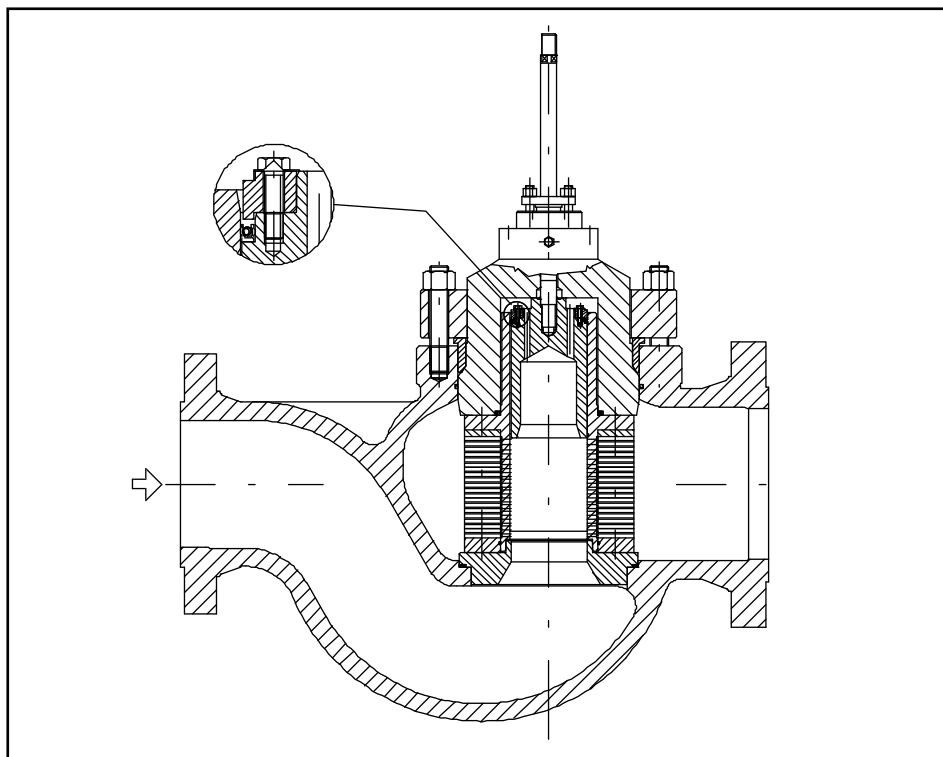

Fig. 13 *Multistage/multipath low noise type reducing valve, provided with the characteristic disk stack - Model suitable for low temperature service, like stations for methane gas pressure 1st stage reduction.*

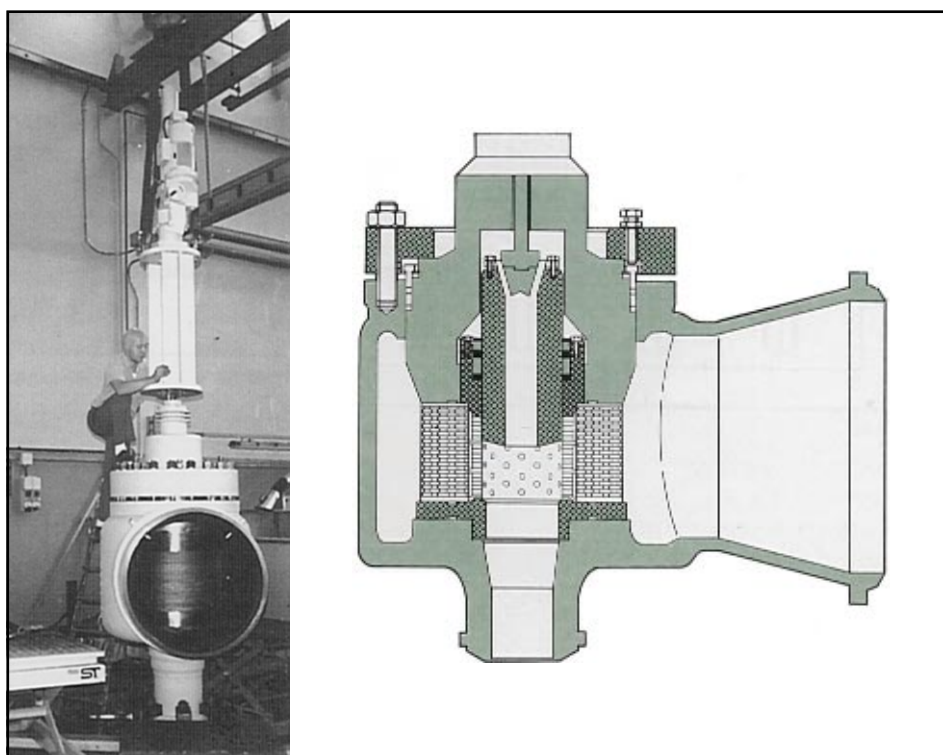

Fig. 14 *Low noise model universal type suitable for service on high temperature steam - The picture shows a very exacting application:
by-pass for condensation turbine DN 12" x 34"
 $p_1 = 100 \text{ bar}$ - $p_2 = 1.5 \text{ bar}$ - max steam flow rate = 250 t/h
-max $L_p = 90 \text{ dB(A)}$ (bare pipe)*

5

PIPING INFLUENCE

Noise prediction of a control valve is affected by the lay-out of the piping where the valve is installed.

Reducers, elbows, on/off valves, branch pipes, etc. contribute to generate noise, like all other causes of turbulence.

Due to the extreme problem complexity it is not possible to base on simple correction equation; just some guidances can be given:

- **Straight pipe lengths**

Minimum straight pipe lengths adjacent to the valve necessary not to affect the expected sound pressure level is:

6 DN upstream and **3 DN downstream**, where DN represents the diameter of the body connection.

Such lengths include the eventual concentric reducers with progressively variable section shown in Fig. 16.

They may be increased by the designer according to the operation heaviness.

- **Reducers**

To avoid additional noise they must have a progressive section change, mainly at the outlet (see Fig. 15). Avoid eccentric fittings.

- **On/off valves**

Where mounted close to the control valve they should be full bore type (ball or gate valves).

- **Elbows, branches and other fittings**

Each sudden flow deviation or flow section changes generate noise. To reduce the acoustic interference of such components it is necessary to improve their design, as shown in Fig. 15.

Fig. 15 Effect of pipe configuration on sound pressure level of the line

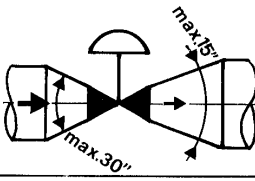
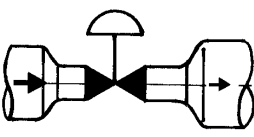
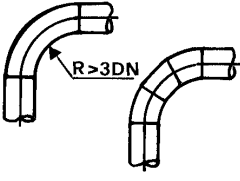
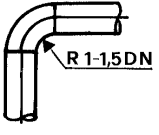
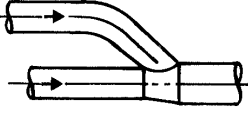
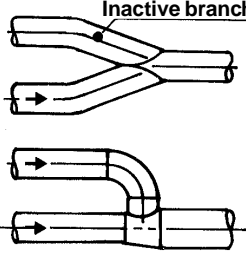
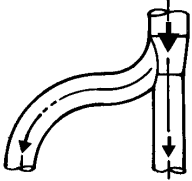
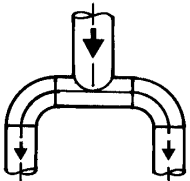
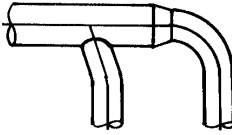
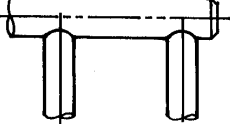
	Suitable	To be avoided
Reducers	 <p>max. 15' max. 30°</p>	
Curves	 <p>$R > 3DN$</p>	 <p>$R 1-1,5DN$</p> <p>(1) Standard curves</p>
Confluences		 <p>Inactive branch</p>
Branches		
Manifolds		

6

EXHAUST TO ATMOSPHERE

The acoustic problem of the discharge of a compressible fluid to the atmosphere where the noise propagates can become very critical, because:

1. The acoustic insulation of the metal wall is missing
2. p_1/p_2 ratio often reaches high values, since the back pressure is zero.

This problem at a glance appears only solvable by installing a silencer (expensive) on each exhaust to the atmosphere.

Luckily this solution can be often avoided for the following reasons:

- The free exhaust can be considered as a punctual source, whose L_p decreases *6 dB by doubling the distance*
- Free exhausts are normally lead to a certain distance from possible hearing places.
- Free exhausts are normally discontinuous (safety valves, start-up of plants, decompression stations, etc.); therefore higher sound levels are allowed for them, compared to the ones allowable for continuous duty equipments. The USA OSHA regulation, for instance, allows a maximum level of 115 dB(A) for a noise exposure of a quarter of hour each eight hours.

Compared to equations used for piped exhausts, in this case the distance from the microphone and its angle from chimney axis, must be also accounted.

Equation (1) can be used to predict the noise generated by vents, by assuming $T_{Lfp} = 0$.

The outlet from the chimney can be considered as a spherical source with 6 dB decreasing when doubling the distance.

However, due to its directional characteristic, the generated noise must be evaluated as a function of the angle between exhaust beam and microphone direction (see Fig. 16).

Here it is the general equation of the sound pressure level:

$$L_{pA_{vent}} = 109 + 10 \cdot \log_{10} \frac{W_a}{r^2} - f_s$$

dove :

where:

- r = distance of the microphone from the chimney top m
- f_s = exhaust style modifier (see Fig. 17 as a function of) dB
- γ = angular deviation of the microphone degrees

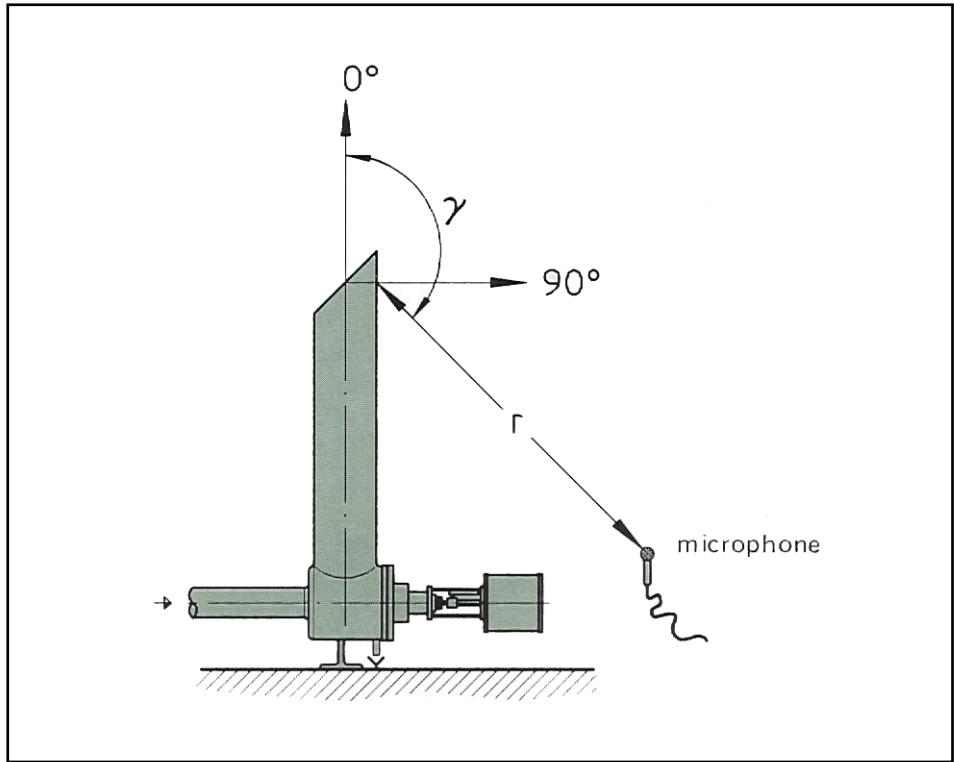

Fig. 16 *Microphone distance*

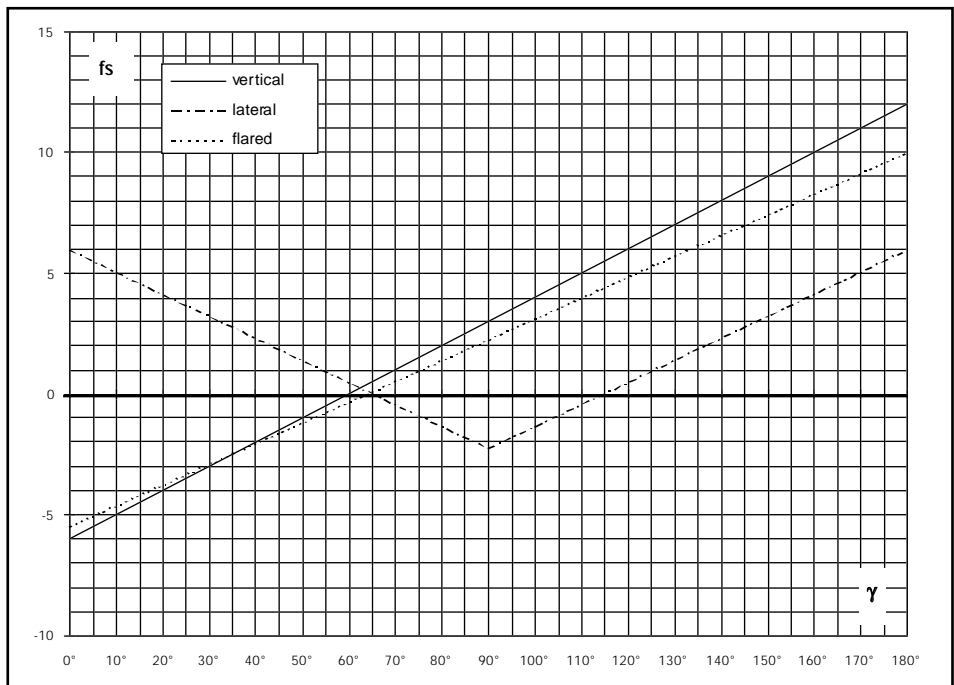

Fig. 17 *Exhaust style modifier - dB*

7

ACOUSTIC INSULATION

The noise generated by the valve propagates along the fluid downstream path without significant loss.

Acoustic insulation can therefore solve the problem only in the area where it is realized.

Piping engineers often mind **thermo-insulating laggings** (very diffused on steam lines), which, **being installed along the whole pipe length**, become interesting under the acoustic viewpoint either.

Fig. 18 shows three typical lagging patterns, whose phono-insulating capacity is shown in Fig. 19.

Unfortunately acoustic insulation performance of such laggings is limited by several reasons related with their installation.

Here are the main ones:

- “acoustic holes” due to also reduced surfaces not lagged
- “acoustic bridges” between pipe wall and outside lagging surface
- “acoustic antennas” constituted by branch lines or holding legs rigidly connected with the piping and passing through the lagging
- laggings not completely sealed or overlapped

These constructive details normally do not affect the efficiency of the thermal insulation, while represent a serious inconvenience as far as the phono-insulating capacity is concerned.

If all the above is added to the noise escape from the unlagged parts of the valve (bonnet and actuator) it can be easily understood how difficult is the solution of the valve acoustic problem by insulation compared to other industrial and civil applications.

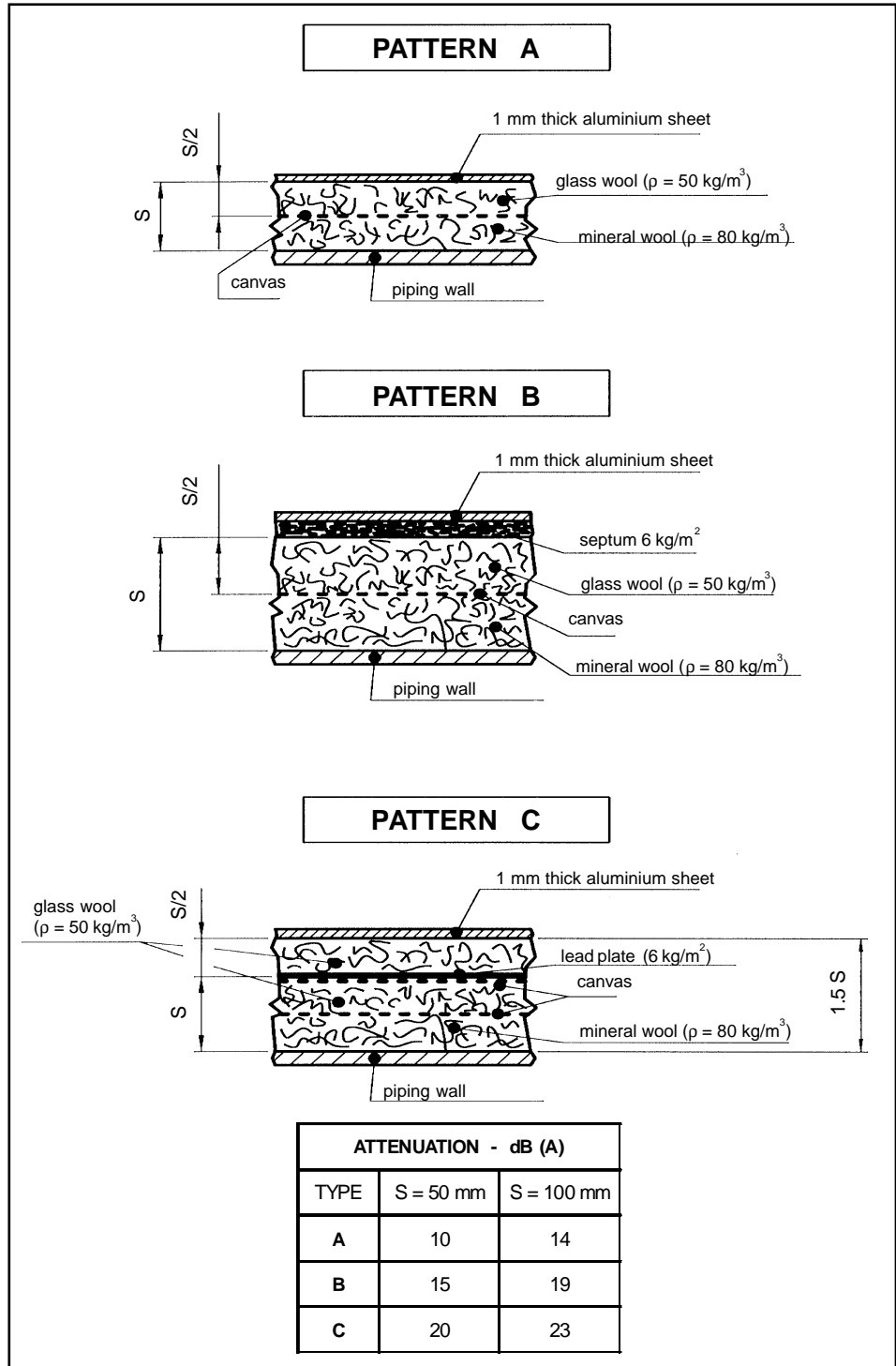

Fig. 18 Patterns of phono/thermo-insulating laggings of piping

NOTES

- “A” pattern is the typical thermal insulation
- “B” and “C” patterns may also be considered as acoustic insulation
- Average attenuations shown in the table are valid for a complete lagging, properly installed and exempt from antennas and acoustic bridges and refer to spectra with prevailing frequencies ranging from 2000 to 8000 Hz. For a more accurate estimation as a function of the actual spectrum taken outside the piping see Fig. 19.
- Actual values are practically lower than theoretical ones (~ 5 dB(A)).

ACOUSTIC ATTENUATION - dB

Insulation thickness	Frequency kHz	Pattern		
		A	B	C
S = 50	0.5	3.3	6.0	8.4
	1	4.3	7.7	10.8
	2	5.2	9.4	13.2
	4	6.2	11.1	15.6
	8	7.1	12.7	17.9
	16	8.1	14.5	20.5
S = 100	0.5	5.5	7.9	9.9
	1	7.0	10.2	12.7
	2	8.6	12.5	15.5
	4	10.1	14.8	18.3
	8	11.6	16.9	20.9
	16	13.3	19.3	23.9

Fig. 19 Acoustic attenuation of the noise outcoming from the pipe, as a function of lagging type (see Fig. 18) and of its thickness -

EIGHT RULES FOR A GOOD ACOUSTIC DESIGN

NOISE PROPAGATES THROUGH DOWNSTREAM PIPING !

Attenuation due to pipe wall is strictly related with its thickness and diameter.

1
2
3
4
5
6
7
8

MIND THE NOISE GENERATED BY FLUID FLOW INSIDE THE PIPING!

High velocities and sudden shape changes can generate high sound pressure levels.

ANISOTROPY INCREASES THE NOISE GENERATED BY THE VALVE!

Presence of walls or other obstacles close to the piping causes the acoustic waves to be reflected, thus increasing the sound pressure level.

ACOUSTIC INSULATION: WHERE

Acoustic insulation solves only locally the noise problem, being negligible the attenuation along the pipe.

INFLUENCE OF ACOUSTIC SPECTRUM

High peak frequency noise is more attenuated by pipe wall. Be careful: the above is only true if the peak frequency is higher than the resonance frequency of the piping.

MIND OTHER NOISE SOURCES

The noise generated by each source sums up with the noise generated by other sources.

ACOUSTIC INSULATION: HOW

Poor insulation, holes and acoustic bridges can considerably reduce the lagging efficiency.

MIND REVERBERATING ENVIRONMENTS

When room dimensions are small and/or acoustic absorption coefficient of walls is very low the background noise can reach considerable values.

Bibliography

- [1] Baumann, H.D. - "A Method for Predicting Aerodynamic Valve Noise Based on Modified Free Jet Noise Theories".
ASME Paper 87 - WA/NCA-7 28, Dicembre 1987 -

- [2] ISA S75.17 - 1989 - "Control valve Aerodynamic Noise Prediction" -

- [3] Fagerlund, A.C. and Chow, D.C., "Sound Transmission Through a Cylindrical Pipe Wall" -
ASME Journal of Engineering for Industry Vol. 103, No 4, November 1981, pp. 355-360 -

- [4] Muroni Paolo - "Le valvole di regolazione per processi industriali" - PEG Milano 1991

- [5] Muroni Paolo - "Le valvole di regolazione a bassa rumorosità per le centrali termiche" -
Convegno ATI / Milano - Novembre 1994

KOSO PARCOL S.r.l. a socio unico
Sede legale: Via Isonzo, 2, 20010 Canegrate (Milano) ITALY
Partita IVA e Codice Fiscale 09684900963
Cap. Soc. €110.000,00 | R.E.A. MI – 2106767
Phone: +39 0331 413111 | Fax: +39 0331 404 215

VECTOR

kentintrol™

RSA

**KOSO
HAMMEL DAHL**